

OKM-30AXP (D)

OKURMA®

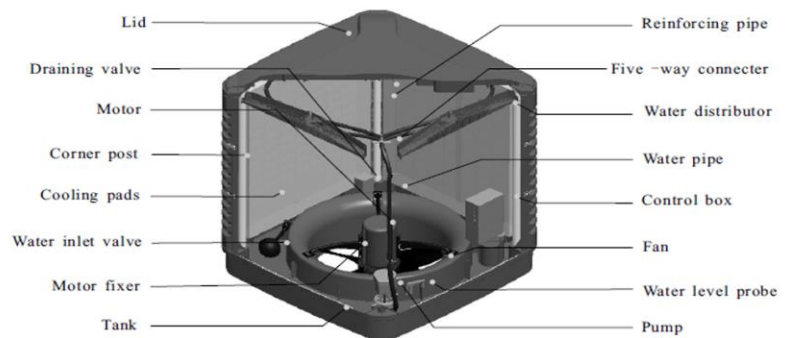
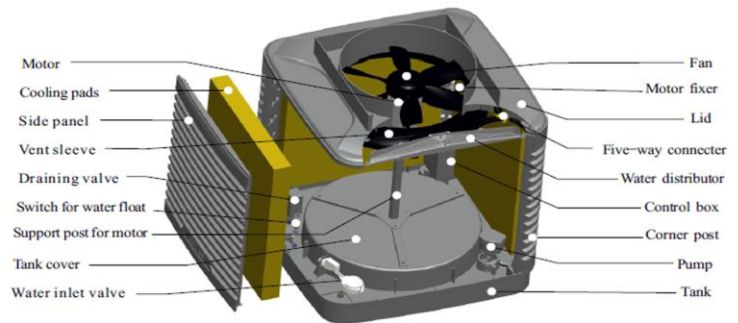

MODEL SPECIFICATIONS:

AIRFLOW (M3/H)	30,000
PRESSURE (PA)	366
OUTPUT (KW)	3
POWER RESOURCES (V/HZ)	415/50
RATED CURRENT (A)	7.1
FAN TYPE	AXIAL
VENT SIZE (L X W) (MM)	765 x 765
FAN SPEED	3 PHASE, MULTISPEED
NET WEIGHT (KG)	125

TARMAH VENTILATION SYSTEM MANUFACTURER SDN. BHD.

ADDRESS : LOT 2286, JALAN BUKIT PASIR, BUKIT PASIR,
83050 BATU PAHAT, JOHOR, MALAYSIA.

CONTACT: +607-431 0923 (Ext.206)

FAX: +607-433 3529

EMAIL: lixfang@tarmah.com.my

(SHIRE LI): +6016-723 0889
(MR. HOO): +6016-338 0248